

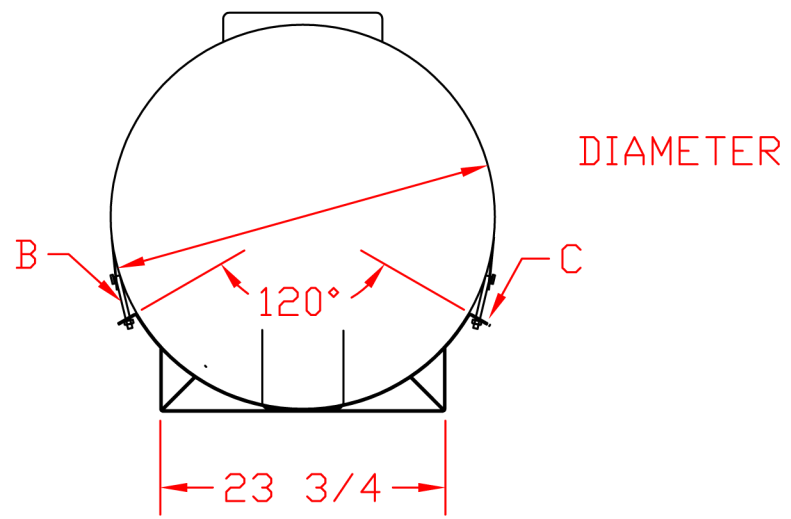

REVISIONS				
ZONE	REV	DESCRIPTION	DATE	APPROVED
	A	WAS BLUE	27FEB02	
	B	WAS J-BOLT	12SEP02	
	C	ADDED 150-30	25JUL06	

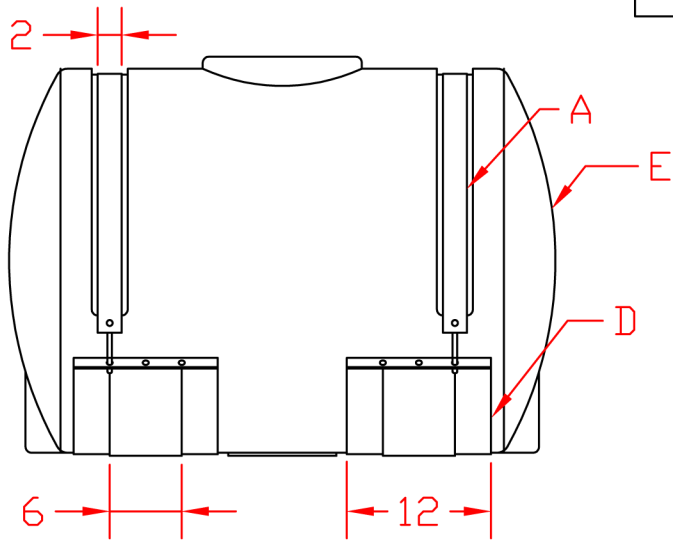

- A: TWO NYLON STRAPS X 72" LONG
- B: FOUR 3/8" X 4 1/2 L-BOLTS W/ NUT, ZINC PLATED (B)
- C: FOUR BUCKLES
- D: TWO SADDLES, 11 GA. HRS, BLACK
- E: TANK--110 X 30 DIA; 150 X 30 DIA; 150 X 32 DIA (C)

		 PEABODY engineering <i>No Boundaries.</i>			
		110-30, 150-30, 150-32 SADDLE ASSY			
JTP	12SEP97	SIZE A	FSCM NO.	DWG NO.	REV C
		SCALE 1/16		SHEET	